

# OUTDOOR BOTTLE FILLER

## SERVICE MANUAL

WALL-MOUNTED VERSION

Manual, Non-refrigerated

DWM-BC

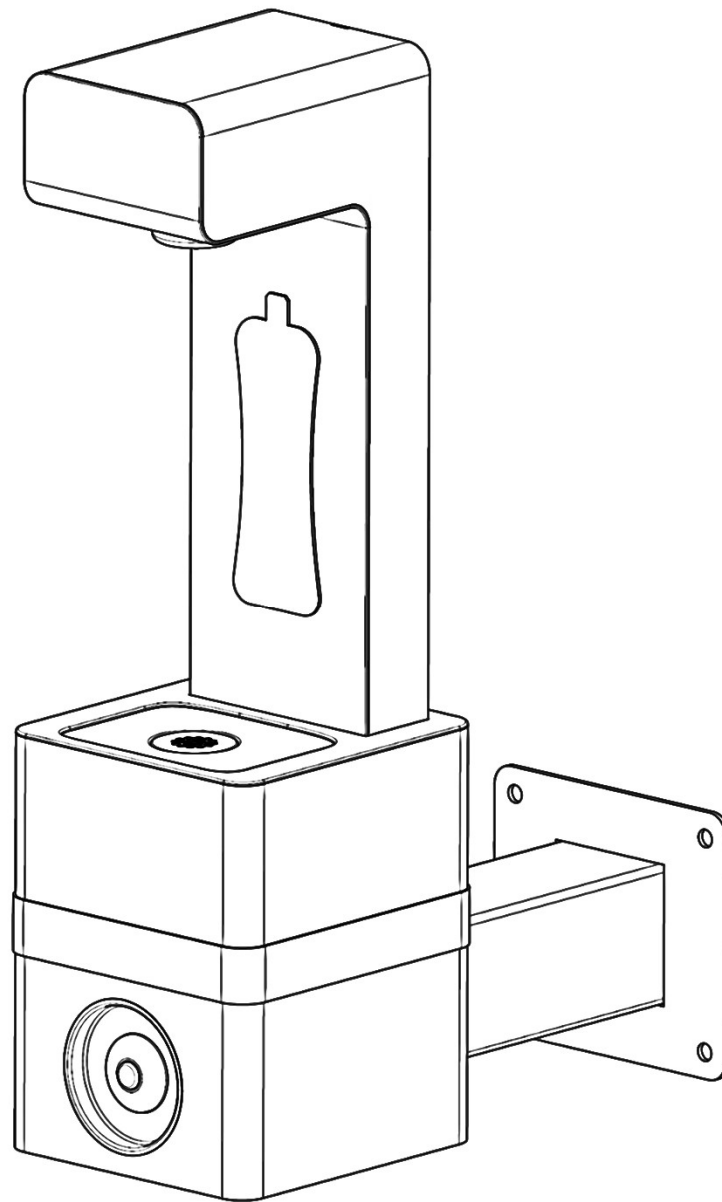

## SECTION 1 – SAFETY INFORMATION

---

**BEFORE YOU START USING THIS BOTTLE FILLER, PLEASE READ THE FOLLOWING INSTRUCTION CAREFULLY.**

**NOTE :** All bottle fillers should be sanitized prior to first use. The appliance is suitable for outdoor use in commercial & industrial locations.

When used in non-temperature controlled environments, unit must be adequately winterized and/or protected from extreme heat to prevent damage where climates dictate.

This appliance is not intended for use by persons (including children) with reduced physical, sensory or mental capabilities, or lack of experience and knowledge, unless they have been given supervision or instruction concerning use of the appliance by the person responsible for their safety.

Children should be supervised to ensure that they do not play with the appliance.

Cleaning and user maintenance shall not be made by children without supervision.

Installation and servicing of the water dispenser should be carried out by an authorized employee.

OASIS will not be responsible for any injury, loss or damage of any kind sustained as a result of misuse of the water dispenser.



**WARNING:** To avoid hazard due to instability of the appliance it must be fixed according instructions.

## SECTION 2 – WATER CIRCUIT

---

Water circuit elements:

POS:	DESCRIPTION:	TOOL SIZE:	QTY:
1A	FITTING, ELBOW TUBE/TUBE ¼”	-	1
1B	FITTING, STRAIGHT TUBE/TUBE ¼”	-	1
2	SCREW – M4x12 socket	⊘ 3 mm	4
3	WASHER – M4 serrated	-	4
4	CARTRIDGE HOLDER	-	1
5	CARTRIDGE EUR (WRAS)	-	1
6	NUT – M5 flanged	⊘ 8 mm	3
7	PUSH BUTTON	-	1
8	BUTTON ADAPTER	-	1
9	FITTING, ELBOW STEM/TUBE ¼”	-	1
10	FITTING, ¾” BSP/TUBE ¼”	-	1
11	NUT – G ¾”	⊘ 36 mm	1
12	WATER OUTLET SLEEVE	-	1
13	PEARLATOR	-	1
14	WATER OUTLET	⊘ 15 mm	1
15	DRAIN PLUG 1 ¼” BSP	-	1
16	GASKET	-	1
17	NUT – 1 ¼” BSP	⊘ 55 mm	1
18	¼” TUBING + INSULATION	-	5 ft

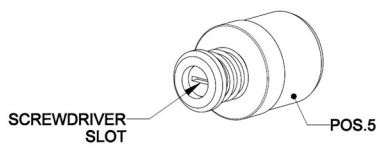
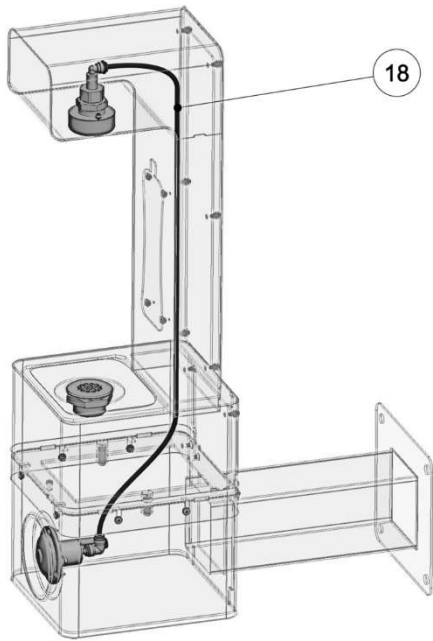

Water flow rate adjustment can be made on cartridge. Turn anti-clockwise to increase flow rate.

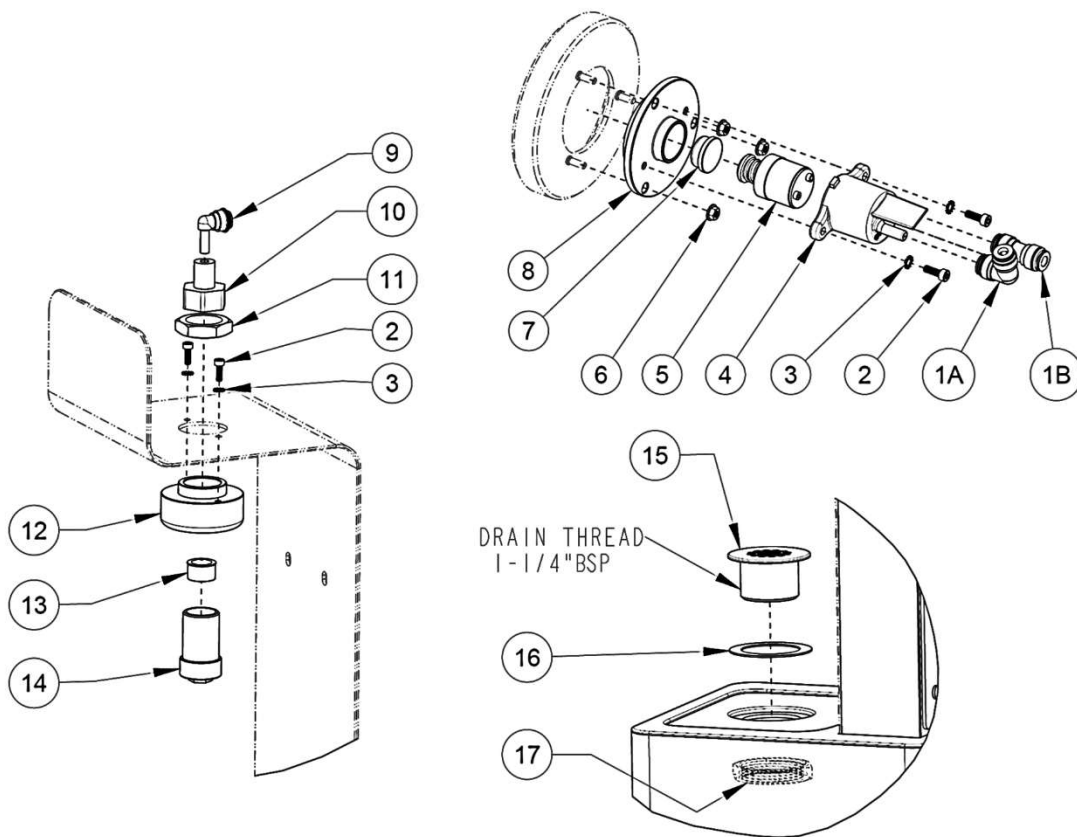

**Fig. 1 – Water circuit elements**

# SECTION 3 – OVERALL DIMENSIONS

NOTE: Dimensions in brackets [] are in millimeters. Unit weight is 19 kg [41,9 lb]

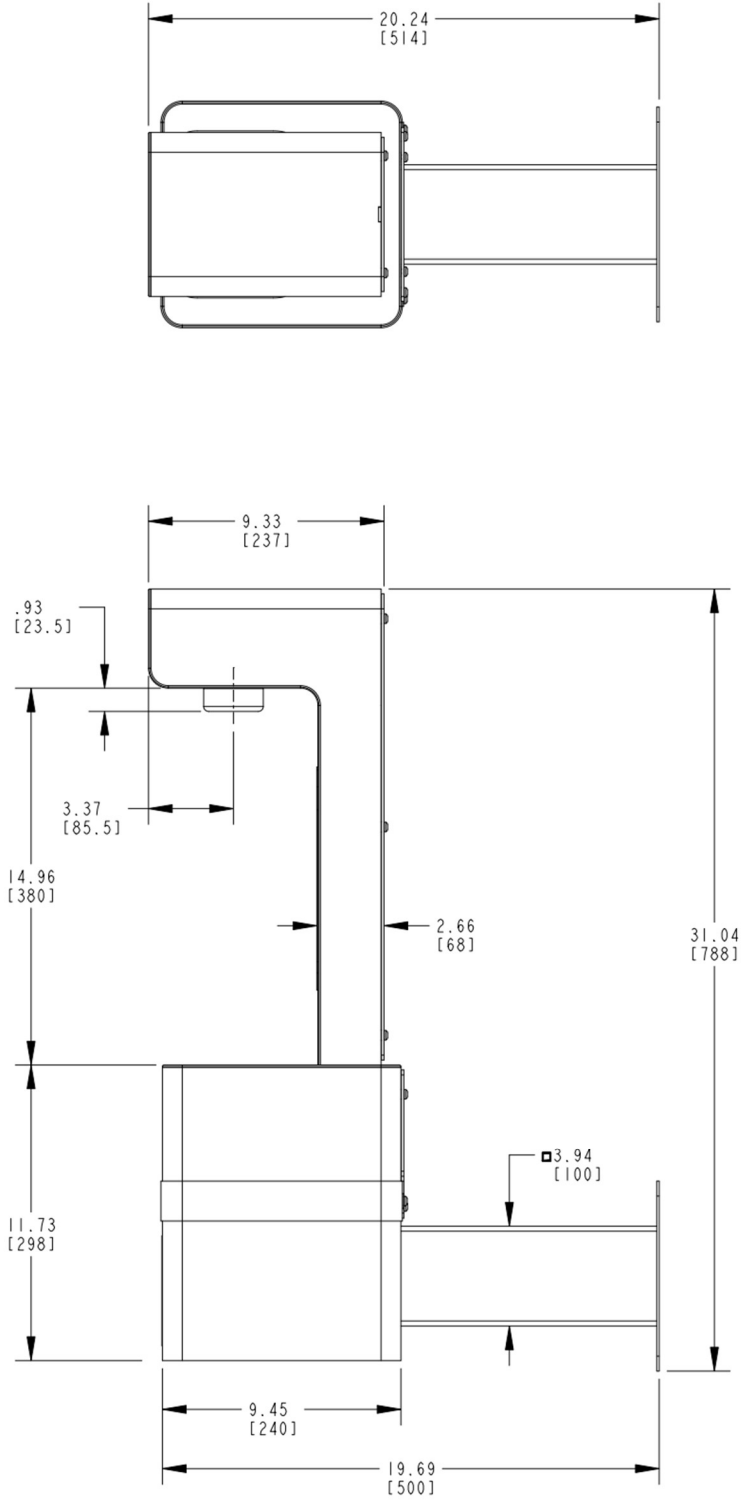
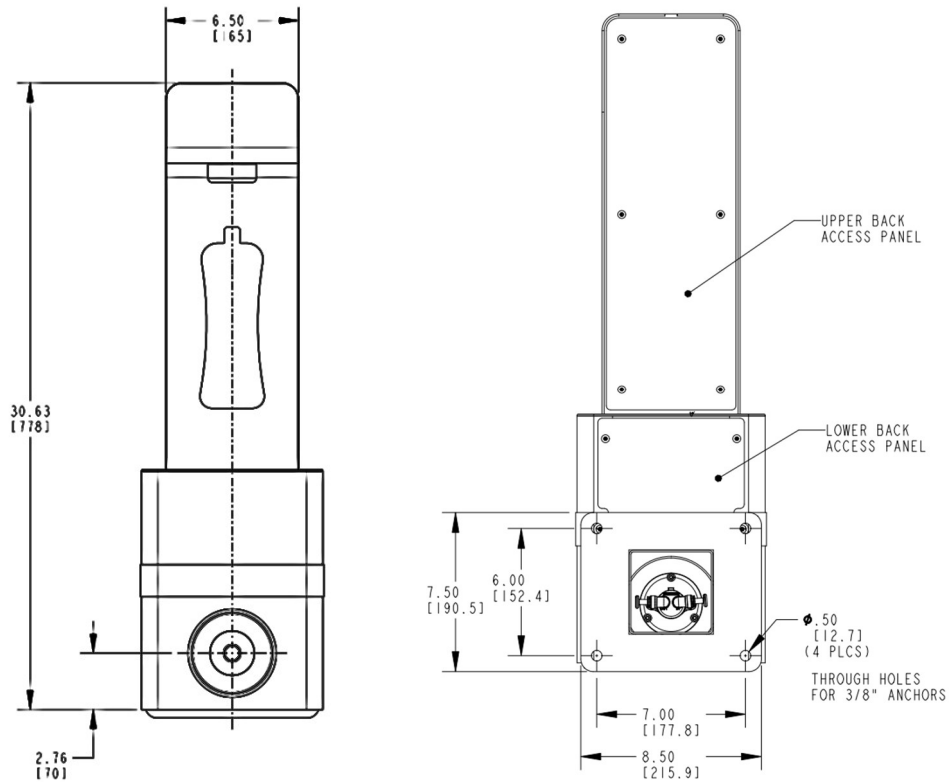

Fig. 2 – Top & Side views

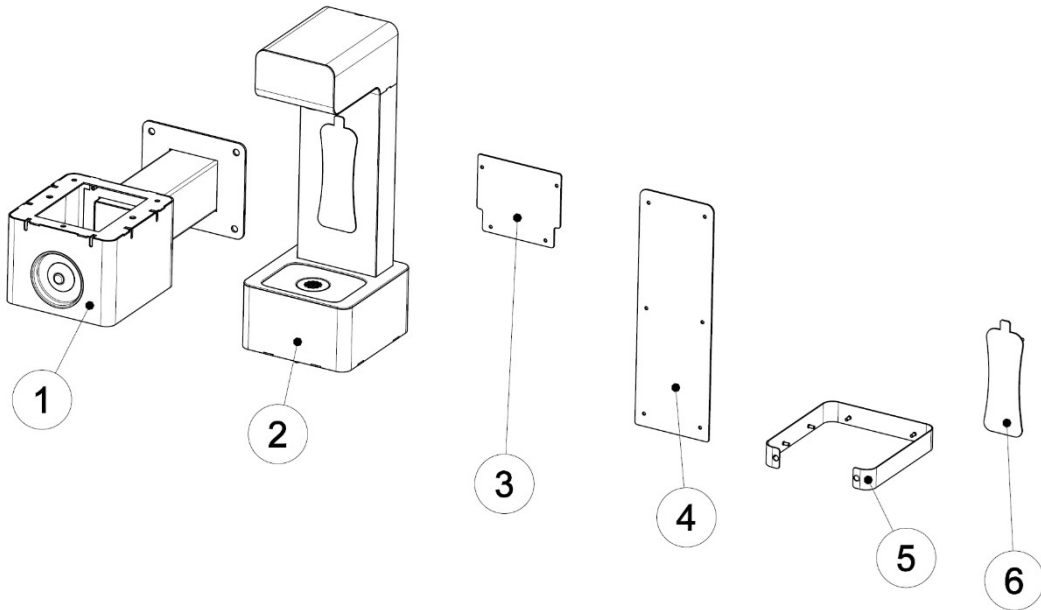

**Fig. 3 – Front & back views**

## SECTION 4 – UNIT INSTALLATION

1. Inspect the carton and bottle filler for evidence of rough handling and concealed damage. Damage claims should be filed with the carrier.
2. Packaging should include following elements:

POS:	DESCRIPTION:	TOOL SIZE:	QTY:
1	ARM ASSEMBLY	-	1
2	ALCOVE ASSEMBLY	-	1
3	LOWER BACK PANEL	-	1
4	UPPER BACK PANEL	-	1
5	AESTHETIC RING	-	1
6	SCREW - M5x12 w/ torx antivandal drive	T25	12
7	SCREW - 3/8"x1,0" hexagonal	⊘ 9/16"	2
8	NUT - 3/8" hexagonal	⊘ 9/16"	4
9	NUT – M5 flanged	⊘ 8 mm	6
10	WASHER - M5	-	2
11	¼" TUBING + INSULATION	-	5 ft
12	INSTRUCTIONS	-	1



**Fig. 4 – Components**

- Slot aesthetic ring [5] onto the arm assembly [1] and secure into position with fasteners [6,9,10].  
It is recommended to fully tighten fasteners after alcove assembly is placed onto the arm assembly (see step 4).

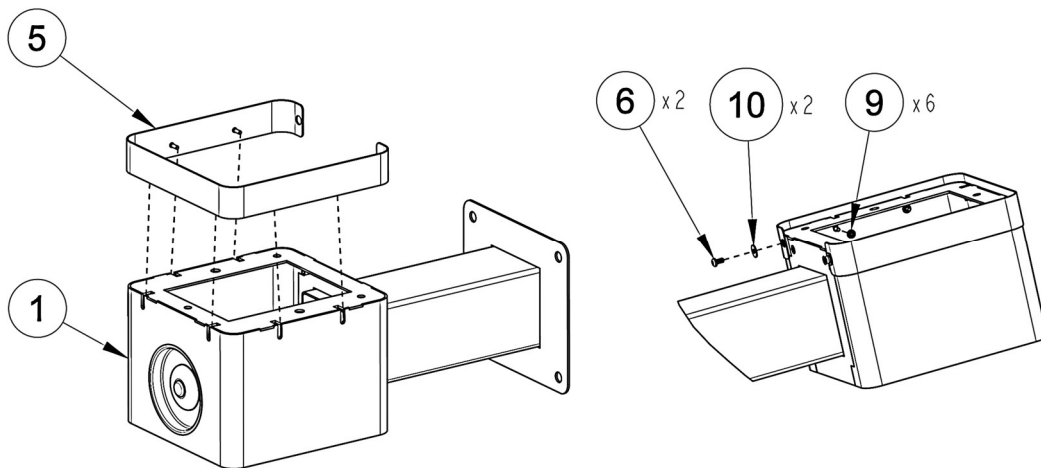

**Fig. 5 – Aesthetic ring assembly**

- Place alcove assembly [2] onto the arm assembly [1] with help of three guiding pins. Secure in place with screws [7] and nuts [8].

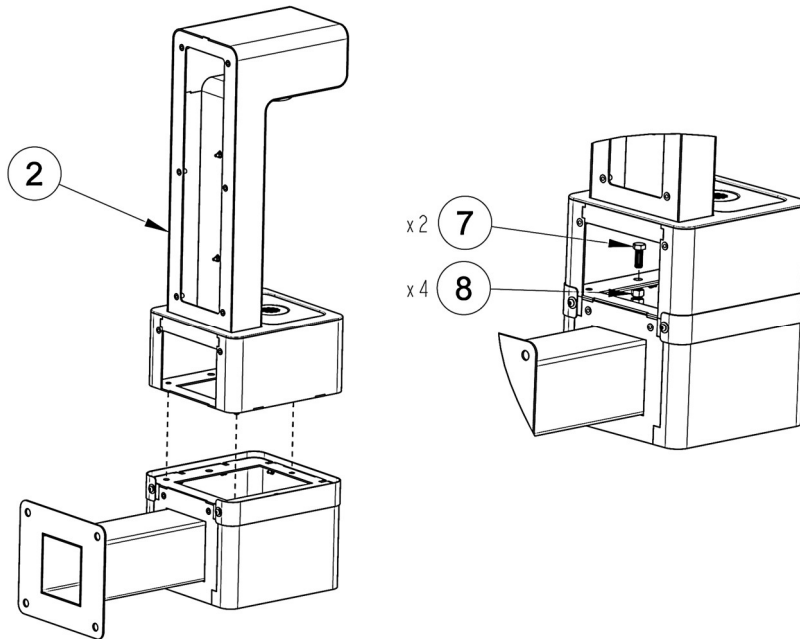

**Fig.6 – Alcove assembly**

- Remove plugs from button assembly inlet & outlet and water outlet inlet. Connect ¼” tube to make water circuit connections. See section 2 for reference. Water drain installation and pressure regulator are not provided by Oasis and are to be installed according to local plumbing code. Water drain connection thread is 1-1/4” NPSL. This outdoor bottle filler is designed to be operated at a water supply line pressure up to 100 PSI (690 kPa). A pressure regulator must be installed in front of the unit’s water inlet if the pressure (including any possible pressure spikes) could exceed 100 PSI (690 kPa).
- Install whole unit to the wall using 3/8” anchors (4 places). Anchors are not included. This bottle filler is to be mounted on a smooth, flat, finished surface with adequate support structure.

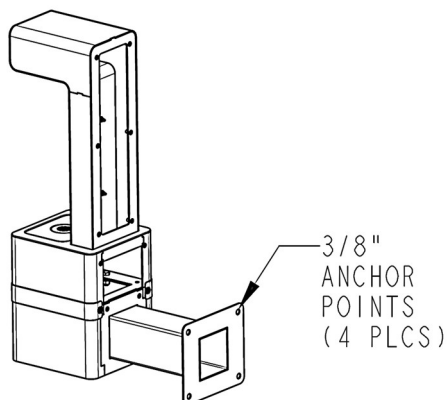

**Fig.7 – Anchor points**

7. Install back panels [3,4] using screws [6]. Use two bottom screws to position lower back panel.

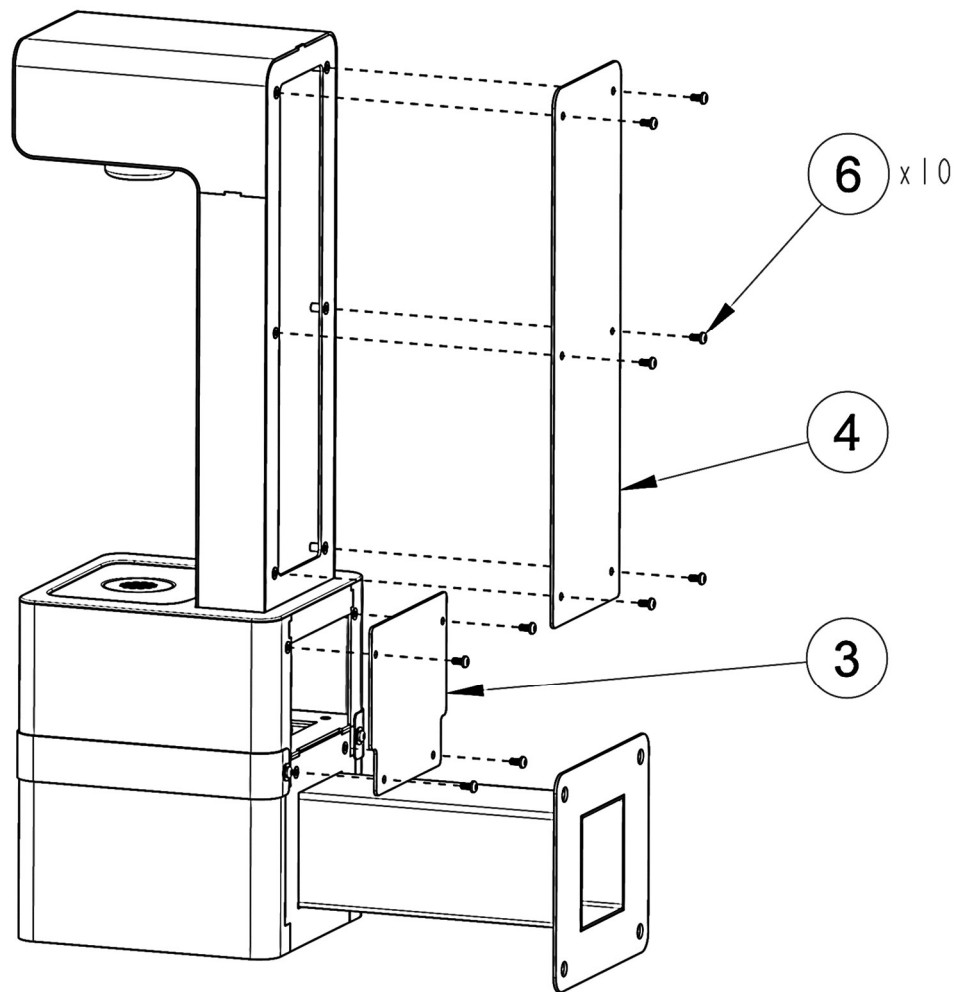

**Fig.8** – Back plates assembly

**OASIS IRELAND**  
Bunree Industrial Est., Ballina,  
Co. Mayo, Ireland F26 D5R3  
+ 353 96 71222  
[www.oasiscoolers.eu](http://www.oasiscoolers.eu) | [info@oasis.ie](mailto:info@oasis.ie)

**OASIS POLAND**  
ul.Gutenberg 20,  
44-164, Gliwice Poland  
+ 48 32 332 65 01