

OUTDOOR BOTTLE FILLER

SERVICE MANUAL

FREE STANDING VERSION

Manual, non-refrigerated

DGM-BC

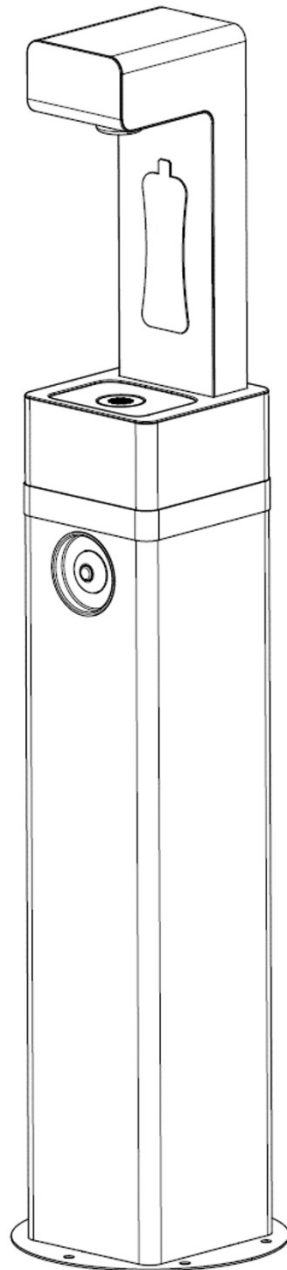

SECTION 1 – SAFETY INFORMATION

BEFORE YOU START USING THIS BOTTLE FILLER, PLEASE READ THE FOLLOWING INSTRUCTION CAREFULLY.

NOTE : All bottle fillers should be sanitized prior to first use. The appliance is suitable for outdoor use in commercial & industrial locations. When used in non-temperature controlled environments, unit must be adequately winterized and/or protected from extreme heat to prevent damage where climates dictate.

This appliance is not intended for use by persons (including children) with reduced physical, sensory or mental capabilities, or lack of experience and knowledge, unless they have been given supervision or instruction concerning use of the appliance by the person responsible for their safety.

Children should be supervised to ensure that they do not play with the appliance. Cleaning and user maintenance shall not be made by children without supervision. Installation and servicing of the water dispenser should be carried out by an authorized employee. OASIS will not be responsible for any injury, loss or damage of any kind sustained as a result of misuse of the water dispenser.



WARNING: To avoid hazard due to instability of the appliance it must be fixed according instructions.

SECTION 2 – WATER CIRCUIT

Water circuit elements:

POS:	DESCRIPTION:	TOOL SIZE:	QTY:
1	FITTING, ELBOW TUBE/TUBE ¼”	-	2
2	SCREW – M4x12 socket	⊘ 3 mm	4
3	WASHER – M4 serrated	-	4
4	CARTRIDGE HOLDER	-	1
5	CARTRIDGE EUR (WRAS)	-	1
6	NUT – M5 flanged	⊘ 8 mm	3
7	PUSH BUTTON	-	1
8	BUTTON ADAPTER	-	1
9	FITTING, ELBOW STEM/TUBE ¼”	-	1
10	FITTING, ¾”BSP/TUBE ¼”	-	1
11	NUT – G ¾”	⊘ 36 mm	1
12	WATER OUTLET SLEEVE	-	1
13	PEARLATOR	-	1
14	WATER OUTLET	⊘ 15 mm	1
15	DRAIN PLUG 1 ¼” BSP	-	1
16	GASKET	-	1
17	NUT – 1 ¼” BSP	⊘ 55 mm	1
18	¼” TUBING + INSULATION	-	5 ft

NOTE: Elements in blue are water contact parts.

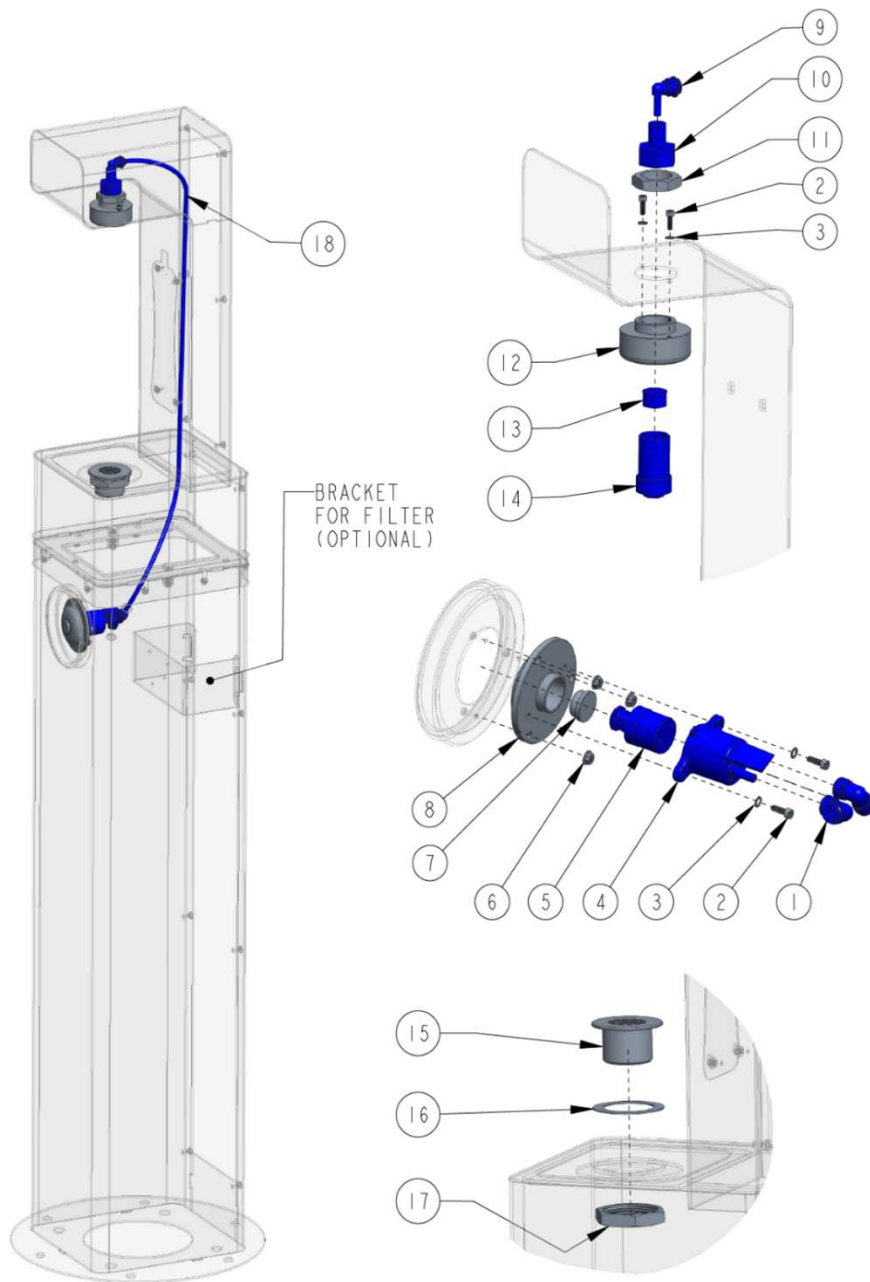
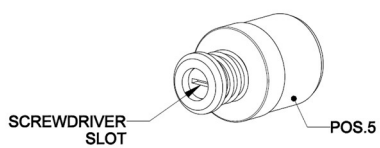

Fig. 1 – Water circuit elements

Water flow rate adjustment can be made on cartridge. Turn counterclockwise to increase flow rate.



SECTION 3 – OVERALL DIMENSIONS

NOTE: Dimensions in brackets [] are in millimeters. Unit weight is 32,1 kg [70,7 lb]

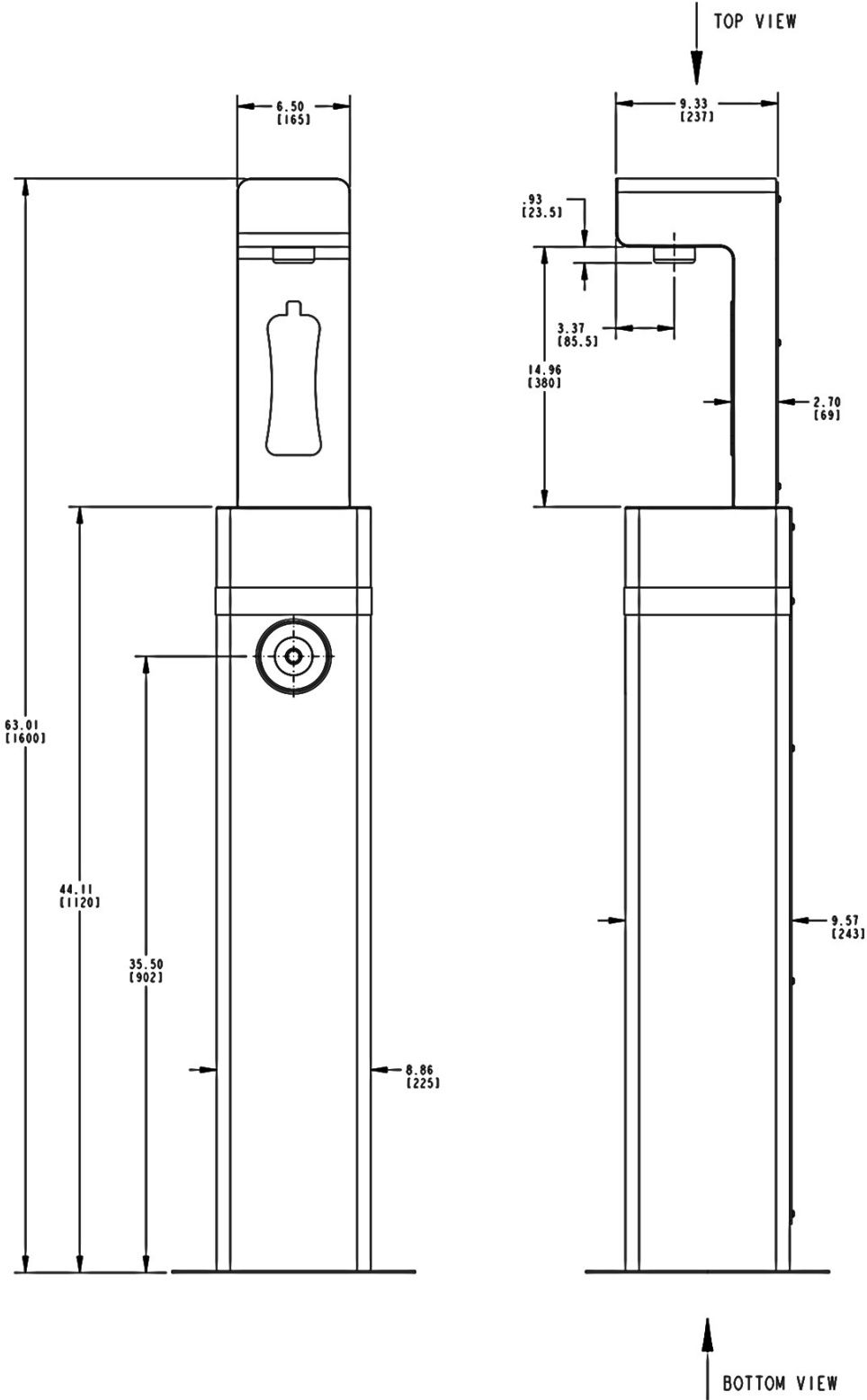

Fig. 2 – Front & Side view

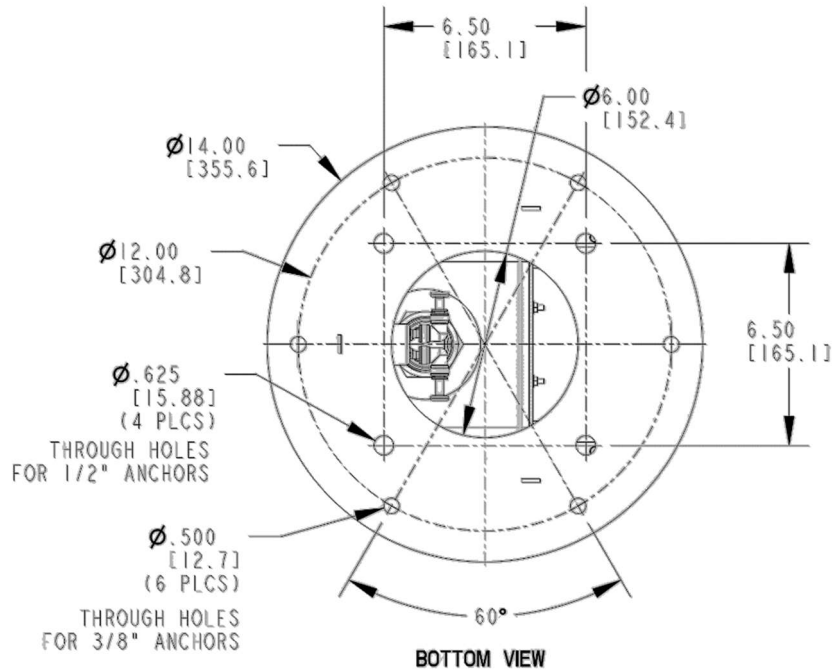

Fig. 3 – Bottom view

SECTION 4 – UNIT INSTALLATION

1. Inspect the carton and bottle filler for evidence of rough handling and concealed damage. Damage claims should be filed with the carrier.
2. Packaging should include following elements:

POS:	DESCRIPTION:	TOOL SIZE:	QTY:
1	COLUMN ASSEMBLY	-	1
2	ALCOVE ASSEMBLY	-	1
3	LOWER BACK PANEL	-	1
4	UPPER BACK PANEL	-	1
5	AESTHETIC RING	-	1
6	SCREW - M5x12 w/ torx antivandal drive	T25	14
7	SCREW - 3/8"x1,0" hexagonal	⊘ 9/16"	2
8	NUT - 3/8" hexagonal	⊘ 9/16"	4
9	NUT – M5 flanged	⊘ 8 mm	6
10	WASHER - M5	-	2
11	¼" TUBING + INSULATION	-	5 ft
12	INSTRUCTIONS	-	1

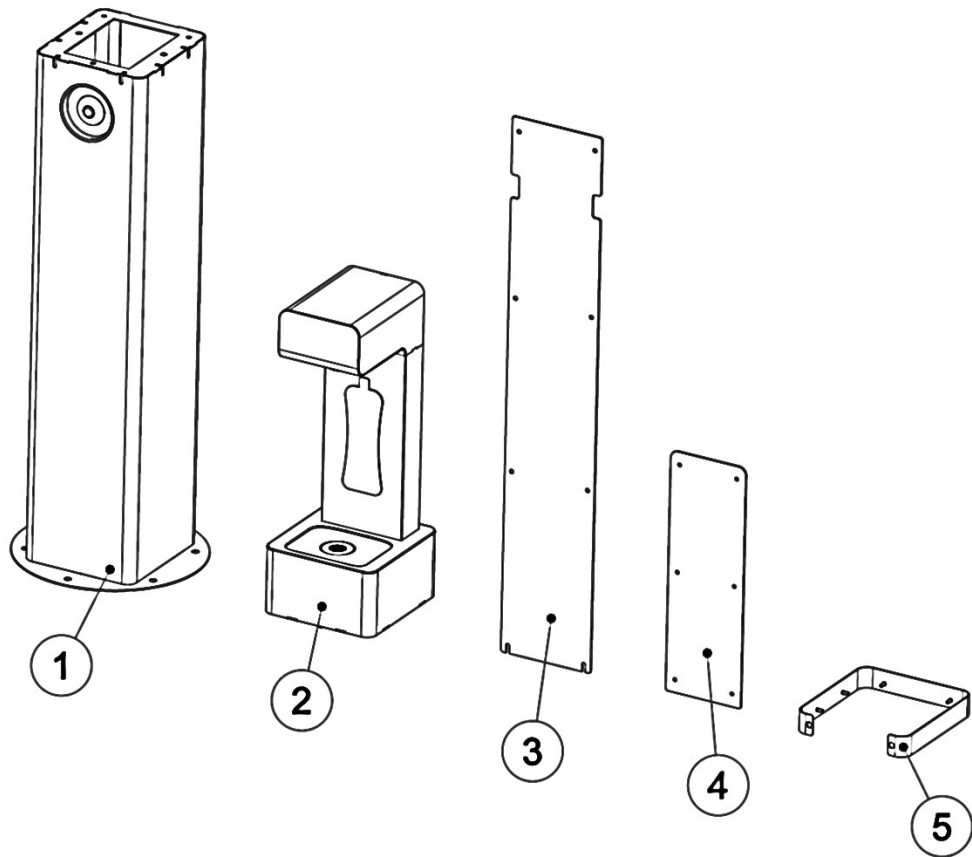

Fig. 4 – Components

3. Slot aesthetic ring [5] onto the column assembly [1] and secure into position with fasteners [6,9,10].

It is recommended to fully tighten fasteners after alcove assembly is placed onto the column assembly (see step 4).

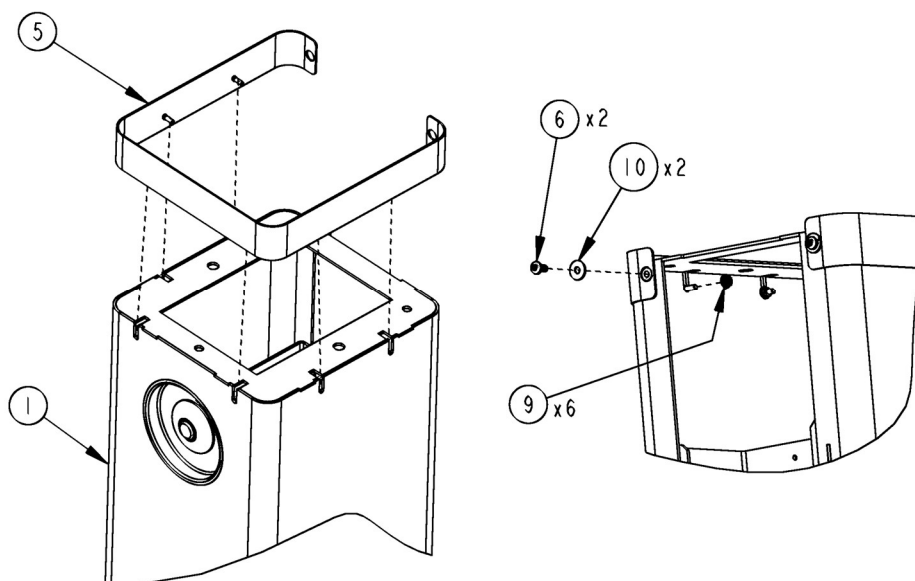

Fig. 5 – Aesthetic ring assembly

4. Place alcove assembly [2] onto the column assembly [1] with help of three guiding pins. Secure in place with screws [7] and nuts [8].

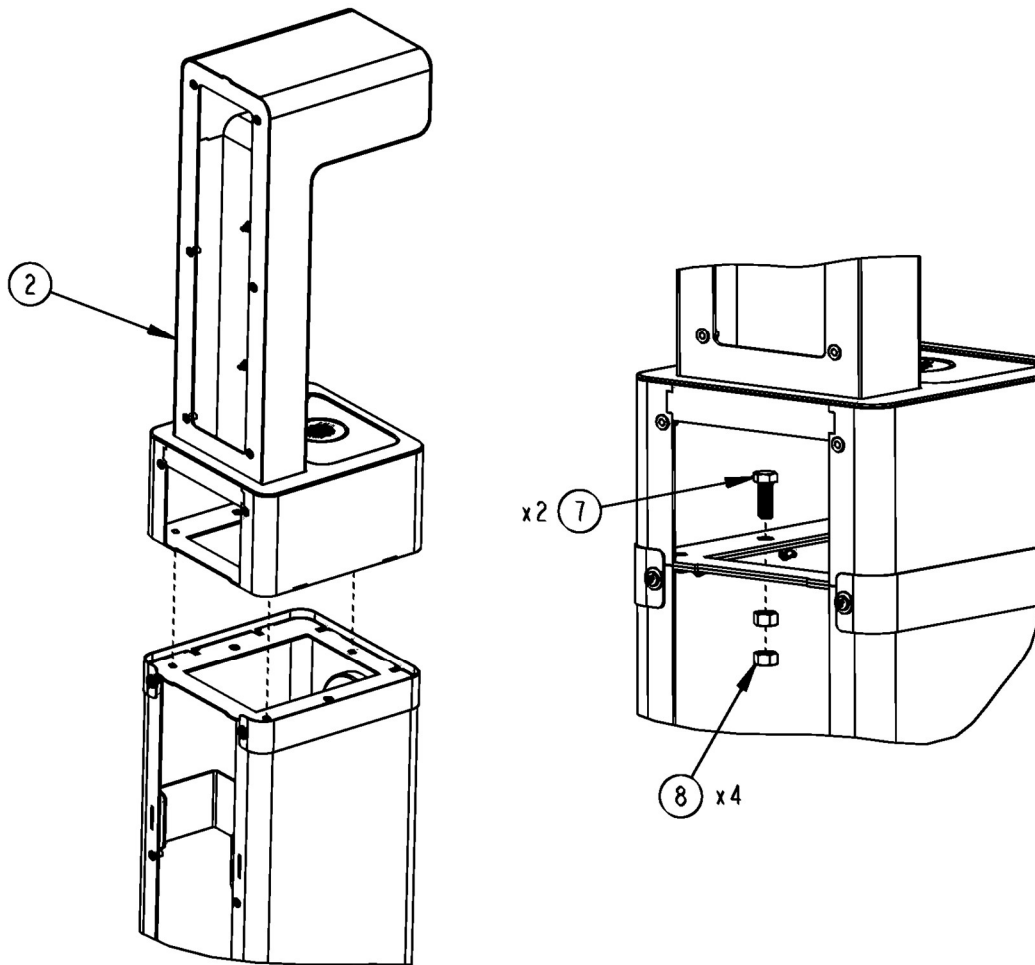

Fig.6 – Alcove assembly

5. Remove plugs from button assembly inlet & outlet and water outlet inlet. Connect $\frac{1}{4}$ " tube to make water circuit connections. See section 2 for reference. Water drain installation and pressure regulator are not provided by Oasis and are to be installed according to local plumbing code. This outdoor bottle filler is designed to be operated at a water supply line pressure up to 100 PSI (690 kPa). A pressure regulator must be installed in front of the unit's water inlet if the pressure (including any possible pressure spikes) could exceed 100 PSI (690 kPa).

- Install whole unit to the ground using 3/8" (6 places) or 1/2" anchors (4 places). See Fig.3 for reference. Anchors are not included. This bottle filler is to be mounted on a smooth, flat, finished surface with adequate support structure. Oasis can provide optional anchor assembly that can be delivered together with the unit. For easy access to the filter (optional) place unit at least 120 mm away from the wall.

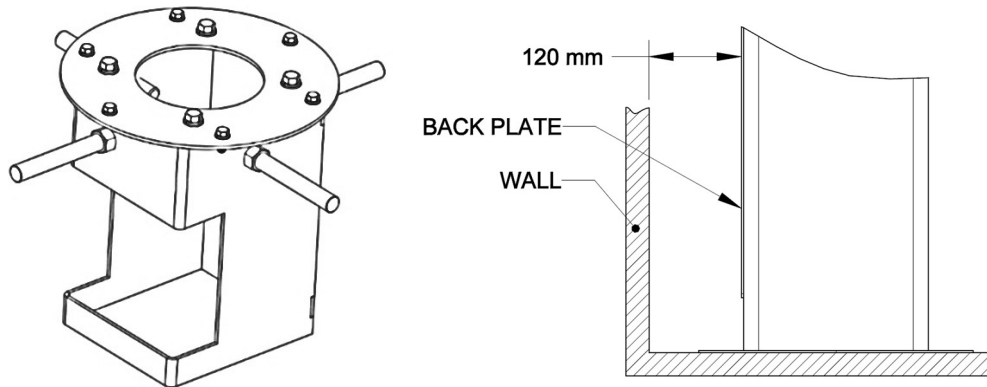

Fig.7 – Optional anchor assembly & filter access guideline

- Install back panels [3,4] using screws [6]. Use two bottom screws to position lower back panel.

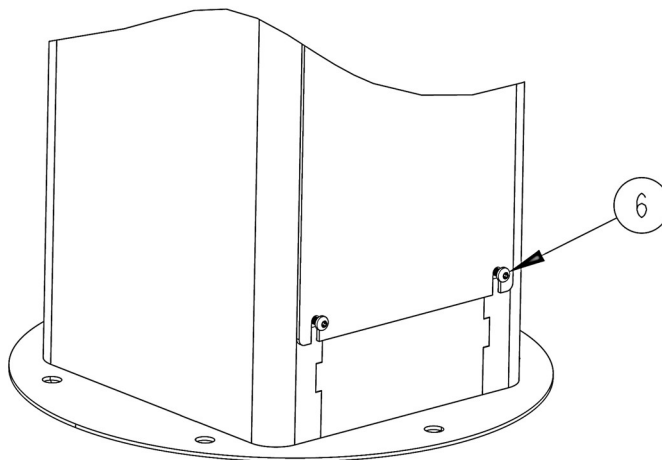

Fig.8 – Lower back panel positioning screws

OASIS IRELAND
 Bunree Industrial Est., Ballina,
 Co. Mayo, Ireland F26 D5R3
 + 353 96 71222
www.oasiscoolers.eu | info@oasis.ie

OASIS POLAND
 ul.Gutenberga 20,
 44-164, Gliwice Poland
 + 48 32 332 65 01