



OUTDOOR DUAL (+1) ■ Manual, Non-Refrigerated Hydration Station Combo

Oasis's Outdoor Dual, combines a bottle filling facility with a bi-level drinking fountain. This is the sustainable hydration solution for park visitors and city goers alike.

This Outdoor Dual requires no electricity, for easy installation and maximum flexibility in placement. Simply activate the unit via one of the push-buttons.

Its vandal-resistant design and corrosion-resistant cabinetry ensure durability in any environment. Designed with an open-sided alcove for easy access, it provides refreshing water wherever it's needed. By offering a sustainable alternative to single-use plastic bottles, the Oasis Outdoor Dual promotes eco-friendly habits and reduces plastic waste and litter.

Also available with two arms.

Available in the following standard colours:

- Forest Green
- Navy
- White.



MODEL CODE	Outdoor Dual (+1)
ACTIVATION	Manual (Push-button)
FILTRATION	Green Filter (optional), Built-in 100 micron strainer
DRAINAGE TYPE	1-1/4" BSP connection.
EXTERIOR DIMENSIONS	Powder coated, 2.5mm marine grade 316 stainless steel
ALCOVE HEIGHT	1600(H) x 725(W) x 355.6(D) [mm]
NET WEIGHT	380 mm
POWER SUPPLY	43 kg
COUNTRY OF ORIGIN	No Electricity Required
CERTIFICATIONS	Poland
WARRANTY	Reg 4 compliant
	1 Year

CONFIG.	ARM SIDE AND POSITION				UNIT SIZE [mm]			ESTIMATED WEIGHT	
	LEFT		RIGHT		HEIGHT	DEPTH	WIDTH	[kg]	[lb]
	LOWER	UPPER	LOWER	UPPER					
1	✓				1600	355,6	~775	43	95
2		✓			1600	355,6	~775	43	95
3			✓		1600	355,6	~775	43	95
4				✓	1600	355,6	~775	43	95
5	✓			✓	1600	355,6	~1195	52	115
6	✓			✓	1600	355,6	~1195	52	115
7		✓		✓	1600	355,6	~1195	52	115
8		✓		✓	1600	355,6	~1195	52	115

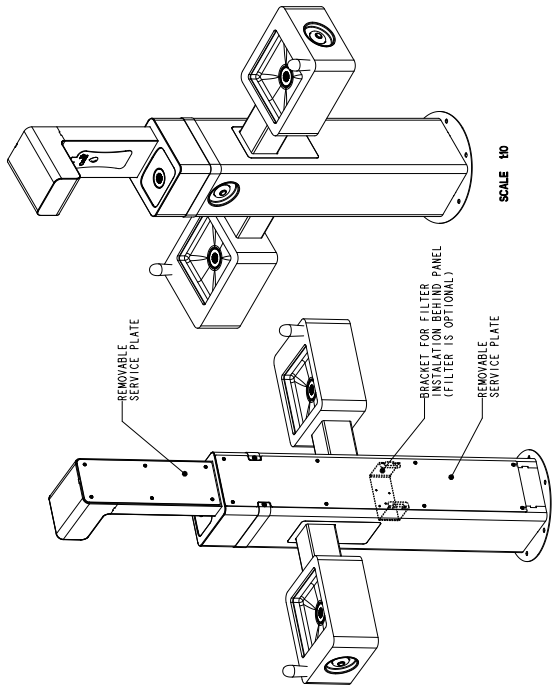
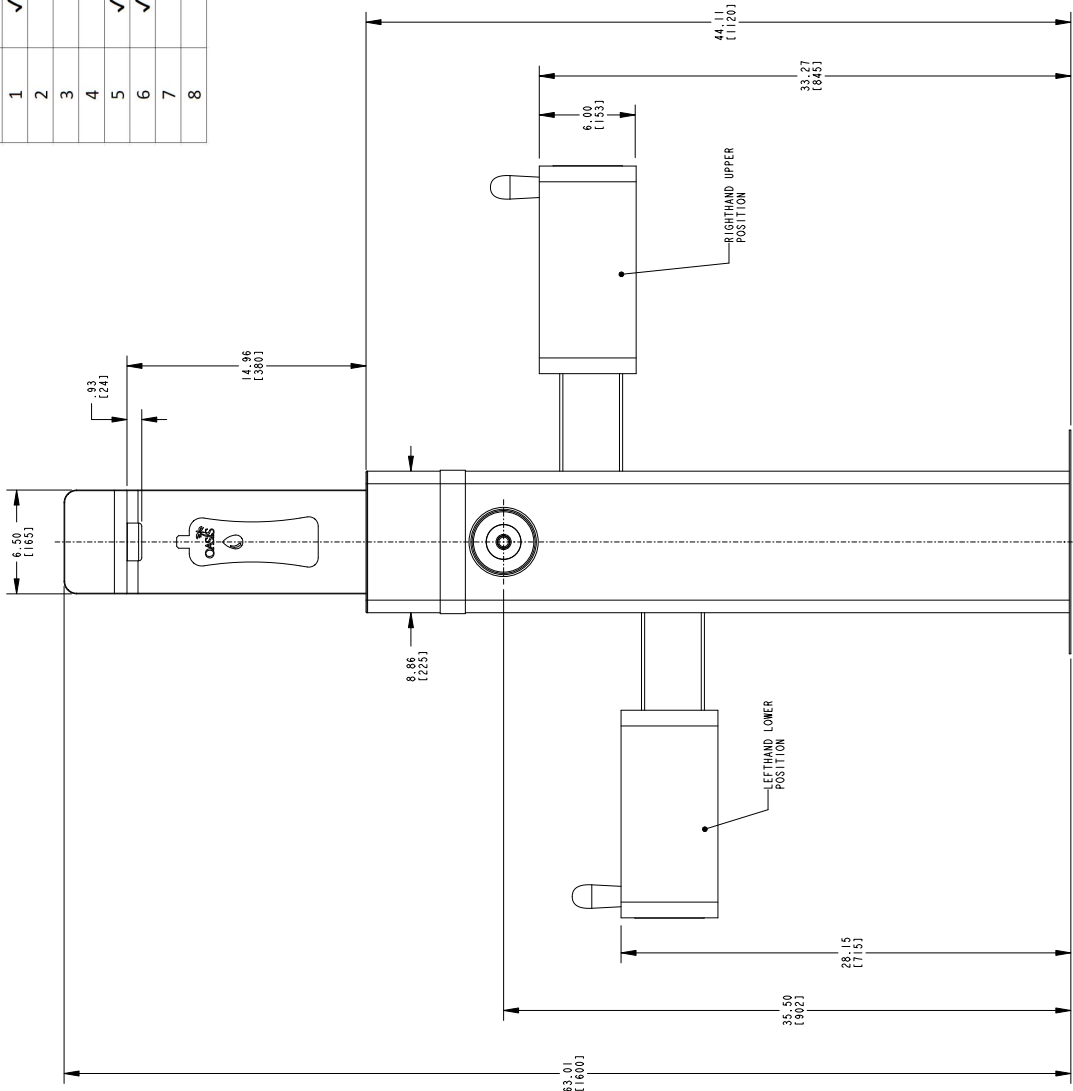

PRELIMINARY

NOTE: 1. DIMENSIONS IN BRACKETS () ARE IN MILLIMETERS.

PRODUCT ENGINEERING
 OASIS INTERNATIONAL
 229 East Campus View Blvd.
 Columbus, Ohio 43235 U.S.A.

DATE CHECKED: 241107TL01
 DRAWN: []
 CHECKED: []
 APPROVED: []

TITLE: OUTDOOR FOUNTAIN
 W/ FOUNTAIN ARM

UNLESS OTHERWISE SPECIFIED:
 DIMENSIONS IN MILLIMETERS

TOLERANCES:
 DECIMALS ±0.25 (0.010)
 FRACTIONS ±1/16 (1.6)
 ANGLES ±0.127

THIRD ANGLE PROJECTION (SIMILAR TO
 FIRST ANGLE PROJECTION)

SCALE: 1:5
 RELEASE CODE: 241107TL01
 SHEET 1 of 2

SEE SHEET 2 FOR ADDITIONAL VIEWS

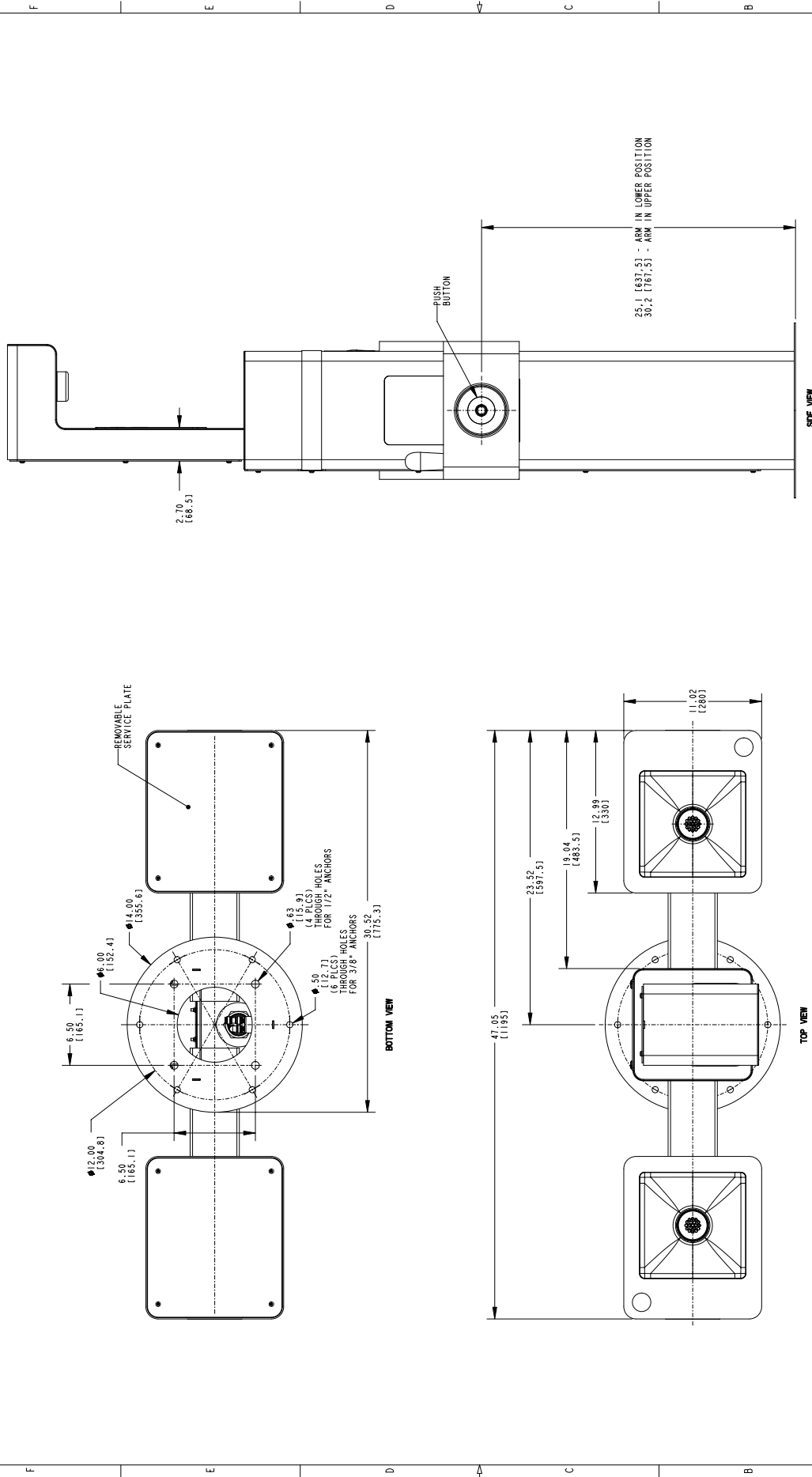

PRELIMINARY

NOTE: I. DIMENSIONS IN BRACKETS [] ARE IN MILLIMETERS.

REV	DATE	BY	CHKD	APPD	DIST. CODE
1					

REV	DATE	BY	CHKD	APPD	DIST. CODE
1					

PROJECT: OUTDOOR FOUNTAIN FREE STANDING W/ FOUNTAIN ARM

SCALE: 1:5

TITLE: OUTDOOR FOUNTAIN FREE STANDING W/ FOUNTAIN ARM

DATE: 24/10/2011

PROJECT NO: 24107TL01

SCALE: 1:5

PROJECT NO: 24107TL01

SHEET 2 OF 2



www.oasiscoolers.eu
info@oasis.ie

OASIS IRELAND
Bunree Industrial Estate, Ballina,
Co. Mayo, F26 D5R3, Ireland.
+353 96 71222

OASIS POLAND
ul.Gutenberga 20,
44-164, Gliwice, Poland
+48 32 332 65 01